

ISSN 2518-1491 (Online),  
ISSN 2224-5286 (Print)

ҚАЗАҚСТАН РЕСПУБЛИКАСЫ  
ҰЛТТЫҚ ҒЫЛЫМ АКАДЕМИЯСЫНЫҢ

Д.В.Сокольский атындағы «Жанармай,  
катализ және электрохимия институты» АҚ

# Х А Б А Р Л А Р Ы

---

---

## ИЗВЕСТИЯ

НАЦИОНАЛЬНОЙ АКАДЕМИИ НАУК  
РЕСПУБЛИКИ КАЗАХСТАН  
АО «Институт топлива, катализа и  
электрохимии им. Д.В. Сокольского»

## NEWS

OF THE ACADEMY OF SCIENCES  
OF THE REPUBLIC OF KAZAKHSTAN  
JSC «D.V. Sokolsky institute of fuel, catalysis  
and electrochemistry»

**SERIES**  
**CHEMISTRY AND TECHNOLOGY**

**2 (434)**

**MARCH - APRIL 2019**

PUBLISHED SINCE JANUARY 1947

PUBLISHED 6 TIMES A YEAR

ALMATY, NAS RK

---

*NAS RK is pleased to announce that News of NAS RK. Series of chemistry and technologies scientific journal has been accepted for indexing in the Emerging Sources Citation Index, a new edition of Web of Science. Content in this index is under consideration by Clarivate Analytics to be accepted in the Science Citation Index Expanded, the Social Sciences Citation Index, and the Arts & Humanities Citation Index. The quality and depth of content Web of Science offers to researchers, authors, publishers, and institutions sets it apart from other research databases. The inclusion of News of NAS RK. Series of chemistry and technologies in the Emerging Sources Citation Index demonstrates our dedication to providing the most relevant and influential content of chemical sciences to our community.*

*Қазақстан Республикасы Ұлттық ғылым академиясы "ҚР ҰҒА Хабарлары. Химия және технология сериясы" ғылыми журналының Web of Science-тің жаңаланған нұсқасы Emerging Sources Citation Index-те индекстелуге қабылданғанын хабарлайды. Бұл индекстелу барысында Clarivate Analytics компаниясы журналды одан әрі the Science Citation Index Expanded, the Social Sciences Citation Index және the Arts & Humanities Citation Index-ке қабылдау мәселесін қарастыруда. Web of Science зерттеушілер, авторлар, баспашылар мен мекемелерге контент тереңдігі мен сапасын ұсынады. ҚР ҰҒА Хабарлары. Химия және технология сериясы Emerging Sources Citation Index-ке енуі біздің қоғамдастық үшін ең өзекті және беделді химиялық ғылымдар бойынша контентке адалдығымызды білдіреді.*

*НАН РК сообщает, что научный журнал «Известия НАН РК. Серия химии и технологий» был принят для индексирования в Emerging Sources Citation Index, обновленной версии Web of Science. Содержание в этом индексировании находится в стадии рассмотрения компанией Clarivate Analytics для дальнейшего принятия журнала в the Science Citation Index Expanded, the Social Sciences Citation Index и the Arts & Humanities Citation Index. Web of Science предлагает качество и глубину контента для исследователей, авторов, издателей и учреждений. Включение Известия НАН РК в Emerging Sources Citation Index демонстрирует нашу приверженность к наиболее актуальному и влиятельному контенту по химическим наукам для нашего сообщества.*

Б а с р е д а к т о р ы  
х.ғ.д., проф., ҚР ҰҒА академигі **М.Ж. Жұрынов**

Р е д а к ц и я а л қ а с ы:

**Ағабеков В.Е.** проф., академик (Белорус)  
**Волков С.В.** проф., академик (Украина)  
**Воротынцев М.А.** проф., академик (Ресей)  
**Газалиев А.М.** проф., академик (Қазақстан)  
**Ергожин Е.Е.** проф., академик (Қазақстан)  
**Жармағамбетова А.К.** проф. (Қазақстан), бас ред. орынбасары  
**Жоробекова Ш.Ж.** проф., академик (Қырғыстан)  
**Иткулова Ш.С.** проф. (Қазақстан)  
**Манташян А.А.** проф., академик (Армения)  
**Пралиев К.Д.** проф., академик (Қазақстан)  
**Баешов А.Б.** проф., академик (Қазақстан)  
**Бүркітбаев М.М.** проф., академик (Қазақстан)  
**Джусипбеков У.Ж.** проф. корр.-мүшесі (Қазақстан)  
**Молдахметов М.З.** проф., академик (Қазақстан)  
**Мансуров З.А.** проф. (Қазақстан)  
**Наурызбаев М.К.** проф. (Қазақстан)  
**Рудик В.** проф., академик (Молдова)  
**Рахимов К.Д.** проф. академик (Қазақстан)  
**Стрельцов Е.** проф. (Белорус)  
**Тәшімов Л.Т.** проф., академик (Қазақстан)  
**Тодераш И.** проф., академик (Молдова)  
**Халиков Д.Х.** проф., академик (Тәжікстан)  
**Фарзалиев В.** проф., академик (Әзірбайжан)

«ҚР ҰҒА Хабарлары. Химия және технология сериясы».

ISSN 2518-1491 (Online),

ISSN 2224-5286 (Print)

Меншіктенуші: «Қазақстан Республикасының Ұлттық ғылым академиясы» Республикалық қоғамдық бірлестігі (Алматы қ.)

Қазақстан республикасының Мәдениет пен ақпарат министрлігінің Ақпарат және мұрағат комитетінде 30.04.2010 ж. берілген №1089-Ж мерзімдік басылым тіркеуіне қойылу туралы куәлік

Мерзімділігі: жылына 6 рет.

Тиражы: 300 дана.

Редакцияның мекенжайы: 050010, Алматы қ., Шевченко көш., 28, 219 бөл., 220, тел.: 272-13-19, 272-13-18,  
<http://chemistry-technology.kz/index.php/en/arithiv>

© Қазақстан Республикасының Ұлттық ғылым академиясы, 2019

Типографияның мекенжайы: «Аруна» ЖК, Алматы қ., Муратбаева көш., 75.

Главный редактор  
д.х.н., проф., академик НАН РК **М. Ж. Журинов**

Редакционная коллегия:

**Агабеков В.Е.** проф., академик (Беларусь)  
**Волков С.В.** проф., академик (Украина)  
**Воротынцев М.А.** проф., академик (Россия)  
**Газалиев А.М.** проф., академик (Казахстан)  
**Ергожин Е.Е.** проф., академик (Казахстан)  
**Жармагамбетова А.К.** проф. (Казахстан), зам. гл. ред.  
**Жоробекова Ш.Ж.** проф., академик (Кыргызстан)  
**Иткулова Ш.С.** проф. (Казахстан)  
**Манташян А.А.** проф., академик (Армения)  
**Пралиев К.Д.** проф., академик (Казахстан)  
**Баешов А.Б.** проф., академик (Казахстан)  
**Буркитбаев М.М.** проф., академик (Казахстан)  
**Джусипбеков У.Ж.** проф. чл.-корр. (Казахстан)  
**Мулдахметов М.З.** проф., академик (Казахстан)  
**Мансуров З.А.** проф. (Казахстан)  
**Наурызбаев М.К.** проф. (Казахстан)  
**Рудик В.** проф., академик (Молдова)  
**Рахимов К.Д.** проф. академик (Казахстан)  
**Стрельцов Е.** проф. (Беларусь)  
**Ташимов Л.Т.** проф., академик (Казахстан)  
**Тодераш И.** проф., академик (Молдова)  
**Халиков Д.Х.** проф., академик (Таджикистан)  
**Фарзалиев В.** проф., академик (Азербайджан)

«Известия НАН РК. Серия химии и технологии».

ISSN 2518-1491 (Online),

ISSN 2224-5286 (Print)

Собственник: Республиканское общественное объединение «Национальная академия наук Республики Казахстан» (г. Алматы)

Свидетельство о постановке на учет периодического печатного издания в Комитете информации и архивов Министерства культуры и информации Республики Казахстан №10893-Ж, выданное 30.04.2010 г.

Периодичность: 6 раз в год

Тираж: 300 экземпляров

Адрес редакции: 050010, г. Алматы, ул. Шевченко, 28, ком. 219, 220, тел. 272-13-19, 272-13-18,  
<http://chemistry-technology.kz/index.php/en/arhiv>

---

© Национальная академия наук Республики Казахстан, 2019

Адрес редакции: 050100, г. Алматы, ул. Кунаева, 142,  
Институт органического катализа и электрохимии им. Д. В. Сокольского,  
каб. 310, тел. 291-62-80, факс 291-57-22, e-mail:orgcat@nursat.kz

Адрес типографии: ИП «Аруна», г. Алматы, ул. Муратбаева, 75

## E d i t o r i n c h i e f

doctor of chemistry, professor, academician of NAS RK **M.Zh. Zhurinov**

## E d i t o r i a l b o a r d :

**Agabekov V.Ye.** prof., academician (Belarus)  
**Volkov S.V.** prof., academician (Ukraine)  
**Vorotyntsev M.A.** prof., academician (Russia)  
**Gazaliyev A.M.** prof., academician (Kazakhstan)  
**Yergozhin Ye.Ye.** prof., academician (Kazakhstan)  
**Zharmagambetova A.K.** prof. (Kazakhstan), deputy editor in chief  
**Zhorobekova Sh.Zh.** prof., academician ( Kyrgyzstan)  
**Itkulova Sh.S.** prof. (Kazakhstan)  
**Mantashyan A.A.** prof., academician (Armenia)  
**Praliyev K.D.** prof., academician (Kazakhstan)  
**Bayeshov A.B.** prof., academician (Kazakhstan)  
**Burkitbayev M.M.** prof., academician (Kazakhstan)  
**Dzhusipbekov U.Zh.** prof., corr. member (Kazakhstan)  
**Muldakhmetov M.Z.** prof., academician (Kazakhstan)  
**Mansurov Z.A.** prof. (Kazakhstan)  
**Nauryzbayev M.K.** prof. (Kazakhstan)  
**Rudik V.** prof., academician (Moldova)  
**Rakhimov K.D.** prof., academician (Kazakhstan)  
**Streltsov Ye.** prof. (Belarus)  
**Tashimov L.T.** prof., academician (Kazakhstan)  
**Toderash I.** prof., academician (Moldova)  
**Khalikov D.Kh.** prof., academician (Tadjikistan)  
**Farzaliyev V.** prof., academician (Azerbaijan)

**News of the National Academy of Sciences of the Republic of Kazakhstan. Series of chemistry and technology.**  
**ISSN 2518-1491 (Online),**  
**ISSN 2224-5286 (Print)**

Owner: RPA "National Academy of Sciences of the Republic of Kazakhstan" (Almaty)

The certificate of registration of a periodic printed publication in the Committee of Information and Archives of the Ministry of Culture and Information of the Republic of Kazakhstan N 10893-Ж, issued 30.04.2010

Periodicity: 6 times a year

Circulation: 300 copies

Editorial address: 28, Shevchenko str., of. 219, 220, Almaty, 050010, tel. 272-13-19, 272-13-18,

<http://chemistry-technology.kz/index.php/en/arhiv>

---

© National Academy of Sciences of the Republic of Kazakhstan, 2019

Editorial address: Institute of Organic Catalysis and Electrochemistry named after D. V. Sokolsky  
142, Kunayev str., of. 310, Almaty, 050100, tel. 291-62-80, fax 291-57-22,  
e-mail: orgcat@nursat.kz

Address of printing house: ST "Aruna", 75, Muratbayev str, Almaty

**NEWS**

OF THE NATIONAL ACADEMY OF SCIENCES OF THE REPUBLIC OF KAZAKHSTAN

**SERIES CHEMISTRY AND TECHNOLOGY**

ISSN 2224-5286

<https://doi.org/10.32014/2019.2518-1491.15>

Volume 2, Number 434 (2019), 31 – 36

**L.K. Tastanova<sup>1</sup>, A.K. Zharmagambetova<sup>2</sup>,  
R.O. Orynbassar<sup>1</sup>, A.K. Apendina<sup>1</sup>, A.K. Zhumabekova<sup>2</sup>**

<sup>1</sup> K. Zhubanov Aktobe Regional State University, Aktobe, Kazakhstan;

<sup>2</sup> D.V. Sokolskii Institute of Fuel, Catalysis and Electrochemistry, Almaty, Kazakhstan  
[lyazzatt@mail.ru](mailto:lyazzatt@mail.ru), [zhalima@mail.ru](mailto:zhalima@mail.ru), [raihan\\_06\\_79@mail.ru](mailto:raihan_06_79@mail.ru), [k.ajngil@mail.ru](mailto:k.ajngil@mail.ru), [araijk@mail.ru](mailto:araijk@mail.ru)

## **POLYVINYLPIRROLIDONE-FERROCYANIDE CATALYSTS FOR CYCLOHEXANE OXIDATION**

**Abstract.** Catalysts for cyclohexane oxidation are developed. Polymer-ferrocyanide catalysts fixed on various mineral supports are prepared by the adsorption method. Properties of synthesized catalysts are studied in cyclohexane oxidation with hydrogen peroxide. Reaction is carried out under mild conditions: at 40 °C and atmospheric pressure. All prepared polymer-metal catalysts supported on inorganic substrates are active in the process of cyclohexane oxidation.

Polymer-metal complex fixed on aluminosilicate Siral-20 shows 14% more activity than the system fixed on Siral-40. However selectivity of catalyst 5%  $K_4[Fe(CN)_6]$ -PVP/Siral-40 is much higher. Under equal conditions, its selectivity for cyclohexanone is 83.4%, whereas selectivity for cyclohexanone of 5%  $K_4[Fe(CN)_6]$ -PVP/Siral-20 is only 61.7%. Catalyst fixed on  $\gamma-Al_2O_3$  demonstrates less activity (25.5%) and selectivity than aluminum silicates (cyclohexanone : cyclohexanol ratio is 1.2 : 1). At the same time, with a sufficiently high selectivity for cyclohexanone (70.4%), 5%  $K_4[Fe(CN)_6]$ -PVP/SiO<sub>2</sub> shows the conversion which is only 17.2%.

The effect of acidic properties of carrier surface on selectivity is studied. It is established that the nature of support (acidic properties of surface) has a significant effect on activity and selectivity of synthesized catalysts.

Polyvinylpyrrolidone-ferrocyanide complex 5% $K_4[Fe(CN)_6]$ -PVP/Siral-40 exhibits the best catalytic properties. The conversion of cyclohexane is 42.9%, selectivity for cyclohexanone is 83.4% and cyclohexanone : cyclohexanol ratio is 5: 1.

**Key words:** polyvinylpyrrolidone, ferrocyanide catalyst, cyclohexane, oxidation, cyclohexanol, cyclohexanone, selectivity.

### **Introduction**

Liquid phase cyclohexane oxidation is an industrially significant process [1,2]. Partial cyclohexane oxidation products - cyclohexanol and cyclohexanone - are used to produce caprolactam, adipic acid, polyamide fibers, nylon-6 and nylon-66 [3,4].

In industry cyclohexane is oxidized by atmospheric oxygen over homogeneous catalytic systems at high temperatures and pressures using toxic solvents. Cobalt, copper, and manganese salts are used as catalysts [5]. At temperatures above 423 K and oxygen pressure up to 3.0 MPa conversion of cyclohexane is 4-15%, selectivity for the sum of cyclohexanone and cyclohexanol is 80–85% [6]. It is quite difficult to carry out reaction of cyclohexane oxidation selectively to cyclohexanol and cyclohexanone which are intermediate products [7-9] of the process.

Selectivity of cyclohexanol and cyclohexanone formation decreases as the degree of initial substance conversion into products rises, therefore in industrial processes in order to increase selectivity it is required to strictly control conversion. In this regard, increasing selectivity of cyclohexanol and cyclohexanone formation with increase in conversion of cyclohexane is a very important challenges of catalysis [10,11].

The problem of saturated hydrocarbons oxidation is associated with high energy consumption for C – H and C – C bonds breaking. In nature reactions of various hydrocarbons oxidation easily proceed with participation of enzymes capable to oxidize with high activity and selectivity non-activated C – H bonds

of hydrocarbons [12–15]. In natural oxygenates hem-iron complex of protoporphyrin plays the role of active center. The iron-porphyrin complex is similar to the complex found in oxygen carriers, hemoglobin and myoglobin, as well as in catalase and peroxidase enzymes.

The increased catalytic activity and selectivity of enzymes initiated research aimed on the development of highly efficient catalysts that act like biocatalysts [16-18].

Polymer-metal complexes exhibit high activity and selectivity in oxidation processes. A very promising is use of synthetic nitrogen-containing polymers, which easily form complexes with metal ions, to create catalytic systems [19]. To increase stability with repeated use of catalytic systems, polymer-metal complexes are applied on organic or inorganic supports [20, 21]. Such systems in many cases combine the advantages of both homogeneous and heterogeneous catalysts [22].

Despite the good catalytic properties of polymer-metal complexes on inorganic supports in various processes of organic synthesis, there are very few studies on their characteristics and use in cycloalkane oxidation reactions. Therefore development of new heterogeneous catalysts based on soluble polymer-metal complexes is of great interest for the processes of cyclohexane oxidation.

To create catalytic systems it is preferable to use nitrogen-containing polymers that easily form complexes with metal ions. One of them is water and ethanol soluble polymer of N-vinylpyrrolidone - polyvinylpyrrolidone (PVP). PVP is highly hydrophilic, has a clear tendency to form complexes and good adhesive properties [23, 24]. Among the important properties of this polymer is its non-toxicity.

Catalytic activity of polyvinylpyrrolidone-ferrocyanide complexes fixed on inorganic supports is investigated in the present work. The effect of acidic properties of carrier surface on selectivity of cyclohexane oxidation is studied.

### Methods

Polymer-ferrocyanide catalysts were prepared by adsorption method based by deposition of 5% of the active phase on substrate mass. Aluminosilicates (Siral-40 with content of SiO<sub>2</sub> 40% and Siral-20 with SiO<sub>2</sub> content 20%), SiO<sub>2</sub> and  $\gamma$ -Al<sub>2</sub>O<sub>3</sub> were used as carriers. Polyvinylpyrrolidone with a molecular weight of 15,000 was used as a macromolecular modifier.

To assess the effectiveness of poly-N-vinylpyrrolidone-ferrocyanide catalyst in oxidation reaction twice distilled chemically pure cyclohexane was used. Purity of substrate was checked by method of chromatography and according to the refraction index. Concentration of substrate in the experiments was  $2.7 \cdot 10^{-3}$  mole/l. 40% solution of hydrogen peroxide was used as oxidizing agent. As a solvent it was used twice distilled chemically pure acetonitrile.

An aqueous solution of polyvinylpyrrolidone containing 0.0522 g of polymer in 5 ml of water was added to the aqueous suspension of carrier (0.5 g of oxide or aluminosilicate in 5 ml of water) at room temperature with constant stirring. Mixture was stirred by magnetic stirrer for 2 hours, after that water solution of potassium ferrocyanide (0.1728 g of salt in 5 ml of water) was added. The resulting system was vigorously stirred for 3 hours, and then left in the mother liquor for 10 hours. The precipitate was washed with a 10-fold volume of water, dried and stored in air at room temperature.

Cyclohexane oxidation was carried out in a laboratory unit (Fig. 1) under mild conditions: at 40 °C and atmospheric pressure.

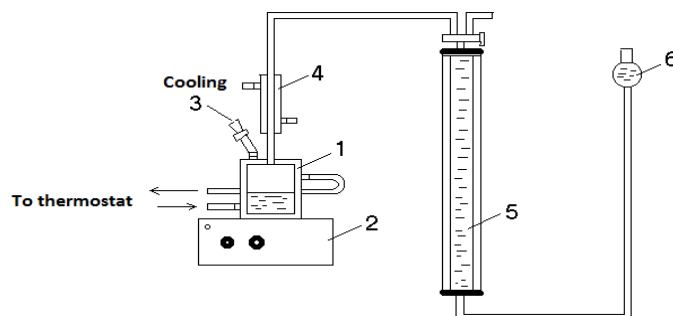

Figure 1 - Volumetric oxidation unit: 1 – thermostatic reactor, 2 – magnetic stirrer, 3 – oxidizer dosing device, 4 – cooler, 5 – measuring burette, 6 – equalizer

A portion of catalyst (0.03 g) was introduced into the reaction vessel with 1.2 ml of acetonitrile. Next, cyclohexane (0.3 ml) and hydrogen peroxide were introduced in the form of 30% aqueous solution, taken in threefold excess with respect to substrate. The reaction mixture was stirred with magnetic stirrer. Oxidation was carried out at 313 K and atmospheric pressure. Reaction mixture was analyzed chromatography after certain periods of time. The amount of released oxygen was determined by volumetric method.

Cyclohexane and products of its oxidation were analyzed by LHM-80M chromatograph with flame ionization detector in isothermal mode. Stainless steel column with length of 3 m and internal diameter of 3 mm was filled with N/W-DMCS chromaton with active phases of 15% Apiezon-L and 3% Carbowax-20M.

### Results and discussion

Synthesized catalysts were studied in reaction of cyclohexane oxidation with hydrogen peroxide. Cyclohexane oxidation is carried out according to the scheme below. Oxygen, which is formed during decomposition of  $H_2O_2$ , is emitted as a gas, and a part of it is consumed for oxidation of cyclohexane:

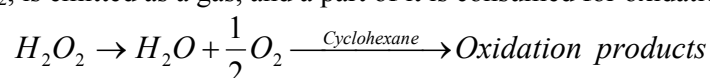

Formation of oxygen-containing compounds – cyclohexanol (-ol) and cyclohexanone (-one) takes place according to reaction:

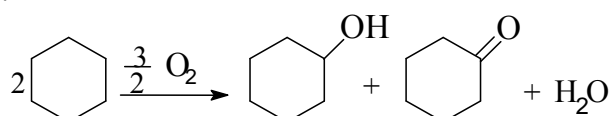

Calculated amount of oxygen required for oxidation of 1 mole of cyclohexane is 0.75 mole. The results of cyclohexane oxidation on synthesized systems are presented in Table 1.

Table 1 - Yield of cyclohexane oxidation\* with  $H_2O_2$  products on catalysts 5%  $K_4[Fe(CN)_6]$ -PVP/support

| Catalysts                                       | Reaction products, % |      | Conversion, % | Selectivity, % |      |
|---|----------------------|------|---------------|----------------|------|
|   | -ol                  | -one |               | -ol            | -one |
| 5% $K_4[Fe(CN)_6]$ -PVP/Siral-40                | 35,8                 | 7,1  | 42,9          | 83,4           | 16,6 |
| 5% $K_4[Fe(CN)_6]$ - PVP /Siral-20              | 30,9                 | 19,2 | 50,1          | 61,7           | 38,3 |
| 5% $K_4[Fe(CN)_6]$ - PVP / $\gamma$ - $Al_2O_3$ | 13,7                 | 11,8 | 25,5          | 54,9           | 45,1 |
| 5% $K_4[Fe(CN)_6]$ - PVP / $SiO_2$              | 12,1                 | 5,1  | 17,2          | 70,4           | 29,6 |

\* Reaction conditions: solvent – acetonitrile, T = 313K, P = 1 atm.

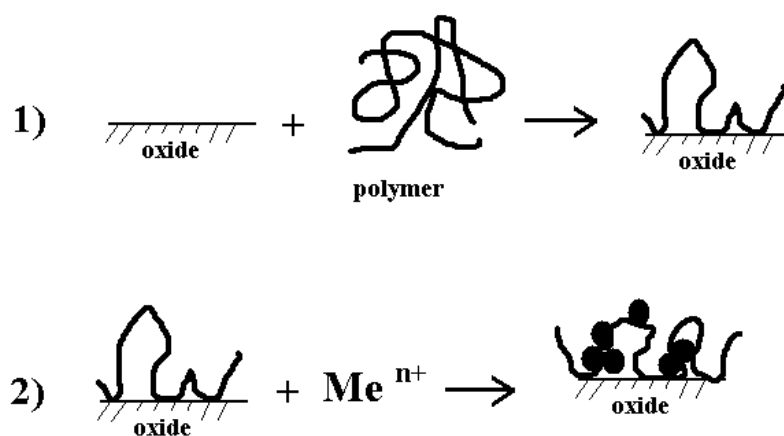

Figure 2 - Scheme of supported polymer-metal complex formation



As can be seen from the data in table, despite the fact that the polymer-metal complex fixed on Siral-20 shows 14% more activity than the system fixed on Siral-40, selectivity of the latter is much higher. Thus, on 5%  $K_4[Fe(CN)_6]$ -PVP/Siral-40 catalyst, selectivity for cyclohexanone is 83.4%, whereas for polymer-metal complex fixed on Siral-20 it is only 61.7%. Catalyst supported by  $\gamma-Al_2O_3$  shows less activity (25.5%) and selectivity than aluminum silicates (cyclohexanone : cyclohexanol ratio is 1.2 : 1). At the same time, with a sufficiently high selectivity for cyclohexanone (70.4%) on 5%  $K_4[Fe(CN)_6]$  - PVP/SiO<sub>2</sub>, conversion is only 17.2%.

Apparently, high selectivity for aldehyde of the process on catalyst supported on Siral-40 is associated with formation of active centers with participation of polymer ligands that contribute to the specific orientation of substrate (Fig. 2), possibly due to the hydrophobic interaction of cyclohexane with macromolecular chains of PVP ("hydrophobic pocket" in metal-enzymes).

It can be stated that the strength of polymer-carrier bond is determined by high donor capacity of nitrogen atom in polymer structure and by cooperative nature of polymer chain segments interaction with the carrier. Degree of acidity of the surface of carrier plays an important role in adsorption of PVP, since this polymer has a nitrogen-containing functional group capable of interacting with acid sites. According to traditional concepts, aluminosilicate has the greatest degree of acidity, and, therefore, a stronger bond PVP - adsorbent forms on this support. As is known, the concept of acid-base bond on the surface of mineral carriers is due to existence of Lewis and Brønsted acid-base centers. These centers serve to adsorb the molecules of various adsorbates. Irreversible adsorption of polymers takes place in the phase of inorganic carrier, which is very important for formation of strongly bonded polymer-metal complexes. In addition, Siral-40 has higher specific surface area (420 m<sup>2</sup>/g) in comparison with other carriers.

### Conclusions

New catalysts based on polymer-ferrocyanide complexes fixed on mineral supports have been developed for the process of cyclohexane oxidation with hydrogen peroxide. It was established that all prepared polymer-metal catalysts supported on inorganic substrates are active in cyclohexane oxidation.

Like biomimetic systems, these catalysts exhibit high activity and selectivity in cyclohexane oxidation under mild conditions. The nature of support affects activity and selectivity of synthesized catalysts. It was established that the acidic properties of the carriers' surface significantly affect selectivity of oxidation process.

The most selective for cyclohexanone is polyvinylpyrrolidone-ferrocyanide complex fixed on aluminosilicate with 40% of SiO<sub>2</sub> (conversion is 42.9%, cyclohexanone : cyclohexanol ratio is 5: 1).

УДК 541.128:678.744

Л.К. Тастанова<sup>1</sup>, А.К. Жармагамбетова<sup>2</sup>,  
Р.О. Орынбасар<sup>1</sup>, А.К. Апендина<sup>1</sup>, А.К. Жумабекова<sup>3</sup>

<sup>1</sup> Актюбинский региональный государственный университет им. К.Жубанова,  
Актобе, пр. А. Молдагуловой, 34;

<sup>2</sup> Институт топлива, катализа и электрохимии им. Д.В. Сокольского, Алматы, ул. Кунаева, 142;

<sup>3</sup> Северо-Казахстанский Университет им. М. Козыбаева, Петропавловск, ул. Пушкина, 86

### ФЕРРОЦИАНИДТІ ПОЛИВИНИЛПИРРОЛИДОН-КАТАЛИЗАТОРЛАРЫНЫҢ ЦИКЛОГЕКСАНДА ТОТЫҒУЫ

**Аннотация.** Циклогександы тотықтыруға арналған катализаторлар дайындалды. Өртүрлі минералды полимерферроцианидті тасымалдағыштарға бекітілген катализаторлар адсорбциялық әдіспен дайындалды. Синтезделген катализаторлар циклогексанның сутегі қос тотығымен тотықтыру реакцияларында зерттелді. Тотықтыру жұмсақ жағдайда (шарттарда), яғни 40<sup>0</sup>С-ға және атмосферлік қысымда жүргізілді. Нәтижесінде барлық дайындалған полимерметалды катализаторлардың (бейорганикалық тасымалдағыштарда) циклогексанның тотығу процесінде белсенділігі артатыны анықталды.

Siral-40 тасымалдағышында дайындалған катализаторға қарағанда Siral-20 алюмосиликатында дайындалған полимерметалдық кешендердің белсенділігі 14%-ға жоғары 5%  $K_4[Fe(CN)_6]$ -ПВПД/Siral-40

катализаторының циклогексан бойынша селективтілігі айтарлықтай жоғары. Себебі 5%  $K_4[Fe(CN)_6]$ -ПВПД/Siral-20-да циклогексан бойынша селективтілік 61,7% тең болғанда сәйкесінше осы жағдайларда (Siral-40 катализаторында) селективтілік 83,4% құрайды.  $\gamma$ -  $Al_2O_3$ -ға дайындалған катализаторлардың белсенділігі алюмосиликаттарға (25,5%) қарағанда төмен (ОН:ОЛ=1,2:1). Осы уақытта 5%  $K_4[Fe(CN)_6]$ -ПВПД/ $SiO_2$

Катализаторында циклогексанның селективтілігі (70,4%) жоғары, конверсия 17,2% құрайды. Тасымалдағыш бетінің қышқылдық қасиетінің процесс селективтілігіне әсері зерттелді. Нәтижесінде тасымалдағыш табиғатының (бетінің қышқылдық қасиеті) синтезделген катализаторлар белсенділігі мен селективтілігіне айтарлықтай әсер ететіндігі анықталды.  $K_4[Fe(CN)_6]$ -ПВПД/Siral-40 поливинилпирролидон – ферроцианидті кешен өте жоғары каталитикалық қасиет көрсетеді. Циклогексанның конверсиясы 42,9%, ОН:ОЛ=5:1 арақатынасында циклогексанның селективтілігі 83,4% тең.

#### Information about authors:

Tastanova L.K. - Acting Associate Professor of the Department of Chemistry and Chemical Technology, K. Zhubanov Aktobe Regional State University, Candidate of Chemical Sciences, tel.: +77013886046, e-mail: lyazzatt@mail.ru. ORCID ID 0000-0002-9236-5909.

Zharmagambetova A.K. - Head of the laboratory of Organic Catalysis, Doctor of Chemical Sciences, Professor, JSC “D.V. Sokolsky Institute of Fuel, Catalysis and Electrochemistry”, Almaty, Kazakhstan. Tel: +77272916972, e-mail: zhalima@mail.ru, ORCID ID 0000-0002-7494-6005.

Orynbassar R.O. - Head of Oil and Gas Department, K. Zhubanov Aktobe Regional State University, Candidate of Chemical Sciences, tel.: +77011482879, e-mail: raihan\_06\_79@mail.ru. ORCID ID. 0000-0002-6198-3018

Apendina A.K. - Head of the Department of Chemistry and Chemical Technology, K. Zhubanov Aktobe Regional State University, Candidate of Chemical Sciences, tel.: +77014169497, e-mail: k.ajngul@mail.ru. ORCID ID 0000-0001-7618-1088.

Zhumabekova A.K. - Professor of the Department of Chemistry and Chemical Technology, M. Kozybayev North Kazakhstan State University, Candidate of Chemical Sciences, tel.: +77773708530, e-mail: zh\_arai@rambler.ru. ORCID ID 0000-0001-6743-8953.

#### REFERENCES

[1] Perkel A L, Voronina S G, Borkina G G. (2018) Liquid-phase oxidation of cyclohexane. Elementary steps in the developed process, reactivity, catalysis, and problems of conversion and selectivity, *Russ Chem Bull*, 67: 1747-1758. DOI: 10.1007/s11172-018-2288-z (in Eng)

[2] Futter C, Prasetyo E, Schunk SA. (2013) Liquid Phase Oxidation and the Use of Heterogeneous Catalysts – A Critical Overview, *Chemie Ingenieur Technik*, 85 SI: 420-436. DOI: 10.1002/cite.201200220 (in Eng)

[3] Bart J C J, Cavallaro S. (2015) Transiting from Adipic Acid to Bioadipic Acid. I, *Petroleum-Based Processes*, *Ind Eng Chem Res*, 54: 1-46. DOI: 10.1021/ie5020734 (in Eng)

[4] Mouanni S, Mazari T, Benadji S, Dermeche L, Marchal-Roch C, Rabia C. (2018) Simple and Green Adipic Acid Synthesis from Cyclohexanone and/or Cyclohexanol Oxidation with Efficient  $(NH_4)_xH_yM_zPMo_{12}O_{40}$  (M: Fe, Co, Ni) Catalysts, *Bull Chem React Eng Catal*, 13: 386-392. DOI: 10.9767/bcrec.13.2.1749.386-392 (in Eng)

[5] Schuchardt U, Cardoso D, Sercheli R, Pereira R, Cruz R S, Guerreiro M C, Mandelli D, Spinace E V, Fires E L. (2001) Cyclohexane oxidation Continues to be a challenge, *Appl Catal A*, 211:1-17. DOI: 10.1016/S0926-860X(01)00472-0 (in Eng)

[6] Castellan A, Bart J C J, Cavallaro S. (1991) Industrial Production and Use of Adipic Acid, *Catal Today*, 9: 237-245. DOI: 10.1016/0920-5861(91)80049-F (in Eng)

[7] Zhou L P, Xu J, Miao H, Wang F, Li X Q. (2005) Catalytic oxidation of cyclohexane to cyclohexanol and cyclohexanone over  $Co_3O_4$  nanocrystals with molecular oxygen, *Appl Catal A*, 292: 223-228. DOI: 10.1016/j.apcata.2005.06.018 (in Eng)

[8] Fang X, Yin Z, Wang H, Li J X, Liang X P, Kang J L, He B Q. (2015) Controllable oxidation of cyclohexane to cyclohexanol and cyclohexanone by a nano- $MnO_x/Ti$  electrocatalytic membrane reactor, *J Catal*, 329: 187-194. DOI: 10.1016/j.jcat.2015.05.004 (in Eng)

[9] Rekkab-Hammoumraoui I, Choukchou-Braham A, Pirault-Roy L, Kappenstein C. (2011) Catalytic oxidation of cyclohexane to cyclohexanone and cyclohexanol by tert-butyl hydroperoxide over Pt/oxide catalysts, *Bull Mater Sci*, 34: 1127-1135. DOI: 10.1007/s12034-011-0157-6 (in Eng)

[10] Wan J, Zhao J, Zhu M Q, Dai H, Wang L. (2011) Selective Oxidation of Cyclohexane to Cyclohexanone and Cyclohexanol over  $Au/Co_3O_4$  Catalyst. *Proceedings of International Conference on Advanced Engineering Materials and Technology*, Sanya, Peoples R China. P. 806. (in Eng)

[11] Hong Y, Sun D L, Fang Y X. (2018) The highly selective oxidation of cyclohexane to cyclohexanone and cyclohexanol over  $-VAIPO_4$  berlinite by oxygen under atmospheric pressure, *Chemistry Central Journal*, 12: 36. DOI: 10.1186/s13065-018-0405-6 (in Eng)

- [12] Eisenmesser E Z, Millet O, Labeikovsky W, Korzhnev D M, Wolf-Watz M, Bosco D A, Skalicky J J, Kay L E, Kern D. **(2005)** Intrinsic dynamics of an enzyme underlies catalysis, *Nature*, 438: 117-121. DOI: 10.1038/nature04105 (in Eng)
- [13] Wang W, Liang A D, Lippard S J. **(2015)** Coupling Oxygen Consumption with Hydrocarbon Oxidation in Bacterial Multicomponent Monooxygenases, *Accounts of Chemical Research*, 48: 2632-2639. DOI: 10.1021/acs.accounts.5b00312 (in Eng)
- [14] Lillerud K P, Olsbye U, Tilset M. **(2010)** Designing Heterogeneous Catalysts by Incorporating Enzyme-Like Functionalities into MOFs, *Topics in Catalysis*, 53: 859-868. DOI: 10.1007/s11244-010-9518-4 (in Eng)
- [15] Kung, H H, Kung M C. **(2014)** Inspiration from Nature for Heterogeneous Catalysis, *Catal Lett*, 144: 1643-1652. DOI: 10.1007/s10562-014-1341-2 (in Eng)
- [16] Silva A R, Mourao T, Rocha J. **(2013)** Oxidation of cyclohexane by transition-metal complexes with biomimetic ligands, *Catal Today*, 203:81-86. DOI: 10.1016/j.cattod.2012.07.043 (in Eng)
- [17] Huang G, Liu Y, Cai J L, Chen X F, Zhao S K, Guo Y A, Wei S J, Li X. **(2017)** Heterogeneous biomimetic catalysis using iron porphyrin for cyclohexane oxidation promoted by chitosan, *Applied Surface Science*, 402: 436-443. DOI: 10.1016/j.apsusc.2017.01.082 (in Eng)
- [18] Antonangelo A R, Bezzu C G, Mughal S S, Malewschik T, McKeown N B, Nakagaki S. **(2017)** A porphyrin-based microporous network polymer that acts as an efficient catalyst for cyclooctene and cyclohexane oxidation under mild conditions, *Catal Comm*, 99: 100-104. DOI: 10.1016/j.catcom.2017.05.024 (in Eng)
- [19] Talgatov E T, Auyezkhanova A S., Tumabayev N Z, Akhmetova S N, Seitkalieva K S, Begmat Y A, Zharmagambetova A K. **(2018)** Polymer-palladium catalysts on magnetic support for hydrogenation of phenylacetylene, *News of the NAS RK. Series of chemistry and technology*, 6:29-37. DOI: 10.32014/2018.2518-1491.23 (in Eng)
- [20] Karasevich E I, Karasevich Y K. **(2000)** Mechanism of cyclohexane oxidation by molecular oxygen in the biomimetic iron porphyrin system with proton and electron donors: I. A radical pathway, *Kinetics and Catalysis*, 41: 485-491. DOI: 10.1007/BF02756064 (in Eng)
- [21] Karasevich E I, Karasevich Y K, **(2002)** Oxidation of cycloalkanes by hydrogen peroxide in a biomimetic iron porphyrin system, *Kinetics and Catalysis*, 43: 19-28. DOI: 10.1023/A:1014284609614 (in Eng)
- [22] Zharmagambetova A K, Auyezkhanova A S, Akhmetova S N, Jardimalieva G I. **(2017)** Oxidation of cyclohexane and n-octane to ketones and alcohols under mild conditions, *News of the National Academy of Sciences of the Republic of Kazakhstan – Series Chemistry and Technology*, 6: 75-80. (in Eng)
- [23] Sidelkovskaya F P. **(1970)** Chemistry of N-vinylpyrrolidone and its polymers. Nauka, Moscow, USSR. (in Russian)
- [24] Haaf F, Sanner A, Straub F. **(1985)** Polymers of N-vinylpyrrolidone – synthesis, characterization and uses, *Polymer J*, 17: 143-152. DOI: 10.1295/polymj.17.143 (in Eng)

## **Publication Ethics and Publication Malpractice in the journals of the National Academy of Sciences of the Republic of Kazakhstan**

For information on Ethics in publishing and Ethical guidelines for journal publication see <http://www.elsevier.com/publishingethics> and <http://www.elsevier.com/journal-authors/ethics>.

Submission of an article to the National Academy of Sciences of the Republic of Kazakhstan implies that the described work has not been published previously (except in the form of an abstract or as part of a published lecture or academic thesis or as an electronic preprint, see <http://www.elsevier.com/postingpolicy>), that it is not under consideration for publication elsewhere, that its publication is approved by all authors and tacitly or explicitly by the responsible authorities where the work was carried out, and that, if accepted, it will not be published elsewhere in the same form, in English or in any other language, including electronically without the written consent of the copyright-holder. In particular, translations into English of papers already published in another language are not accepted.

No other forms of scientific misconduct are allowed, such as plagiarism, falsification, fraudulent data, incorrect interpretation of other works, incorrect citations, etc. The National Academy of Sciences of the Republic of Kazakhstan follows the Code of Conduct of the Committee on Publication Ethics (COPE), and follows the COPE Flowcharts for Resolving Cases of Suspected Misconduct ([http://publicationethics.org/files/u2/New\\_Code.pdf](http://publicationethics.org/files/u2/New_Code.pdf)). To verify originality, your article may be checked by the Cross Check originality detection service <http://www.elsevier.com/editors/plagdetect>.

The authors are obliged to participate in peer review process and be ready to provide corrections, clarifications, retractions and apologies when needed. All authors of a paper should have significantly contributed to the research.

The reviewers should provide objective judgments and should point out relevant published works which are not yet cited. Reviewed articles should be treated confidentially. The reviewers will be chosen in such a way that there is no conflict of interests with respect to the research, the authors and/or the research funders.

The editors have complete responsibility and authority to reject or accept a paper, and they will only accept a paper when reasonably certain. They will preserve anonymity of reviewers and promote publication of corrections, clarifications, retractions and apologies when needed. The acceptance of a paper automatically implies the copyright transfer to the National Academy of Sciences of the Republic of Kazakhstan.

The Editorial Board of the National Academy of Sciences of the Republic of Kazakhstan will monitor and safeguard publishing ethics.

Правила оформления статьи для публикации  
в журнале смотреть на сайте:

[www.nauka-nanrk.kz](http://www.nauka-nanrk.kz)

<http://chemistry-technology.kz/index.php/en/arhiv>

**ISSN 2518-1491 (Online), ISSN 2224-5286 (Print)**

Редакторы: *М. С. Ахметова, Т. А. Апендиев, Аленов Д. С.*  
Верстка на компьютере *А. М. Кульгинбаевой*

Подписано в печать 04.04.2019.  
Формат 60x88<sup>1/8</sup>. Бумага офсетная. Печать – ризограф.  
4 п.л. Тираж 300. Заказ 2.